



## IJRTSM

### INTERNATIONAL JOURNAL OF RECENT TECHNOLOGY SCIENCE & MANAGEMENT

#### “COMPUTATION FLUID DYNAMIC ANALYSIS WITH DIFFERENT PARAMETER ON WATER NOZZLE”

Abhishek Kumar <sup>1</sup>, Rajneesh Kumar Gedam <sup>2</sup>

<sup>1</sup>PG, Scholar, Dept. of Mechanical Engineering, RKDF-CT, Bhopal, MP, India

<sup>2</sup>Associate Professor, Dept. of Mechanical Engineering, BERI, Bhopal, MP India India

#### ABSTRACT

*The design of a fountain provides an excellent opportunity as a multidisciplinary project for engineering and art students. In this project, detailed design of an outdoor fountain nozzle is presented. The fountain produces simple shape with water jets. Here the fountain comprises of 230 individual nozzles. Each nozzle is of convergent type having a tapered end. The 3D model of nozzle was made on CATIA which is a design software and its full name is computer aided three-dimensional interactive application. The CFD analysis of two nozzles with 2mm & 2.5mm diameter respectively was performed on ANSYS which is a computer analysis software provides simulation of product with the help of finite elements method. The boundary condition was applied same as that of the original condition and the results of CFD analysis was studied thoroughly. During the CFX analysis each variable was analysed like velocity, pressure, viscosity, temperature, Turbulence kinetic energy & Eddy Dissipation. The comparative study of two nozzles was made and the maximum & minimum values were tabulated.*

**Keyword:** CFX, Convergent Nozzle, CATIA, ANSYS, FEM, Water fountains

#### I. INTRODUCTION

A fountain (from the Latin "fons" (genitive "fontis"), a supply or spring) may be a piece of design that pours water into a basin or jets it into the air to provide drinking water and/or for an ornamental or dramatic result.

Fountains were originally strictly practical, connected to springs or aqueducts and went to give drinkable and water for bathing and laundry to the residents of cities, cities and villages. till the late nineteenth century most fountains operated by gravity, and required a supply of water over the fountain, like a reservoir or conduit, to create the water flow or jet into the air. Fountains are used nowadays to brighten town parks and squares; to honour people or events; for recreation and for amusement. Fountains will themselves even be musical instruments via by obstruction of 1 or additional of their water jets.

From Roman times till the tip of the nineteenth century, fountains operated by gravity, requiring a supply of water over the fountain itself to create the water flow. The larger the distinction between the elevation of the supply of water and also the fountain, the upper the water would go upwards from the fountain.

In trendy fountains a filter, usually a media filter, removes particles from the water—this filter needs its own pump to force water through it and plumbing to get rid of the water from the pool to the filter and so back to the pool. The water may have chlorination or anti-algal treatment, or might use biological strategies to filter and clean water.

## II. PROBLEM IN BRAKE CALIPERS

1. The function of nozzle problem is minor initially , so are often ignored. With change of the throat, the change of spray characteristics is gradually obvious, and can be monitored.
2. Nozzle wear or corrosion , the flow increase, the pressure drops, resulting larger spray particles. This problem usually can not be found, but can be analyzed through the application of the results.

## III. OBJECTIVE

Since we are using convergent nozzle having bigger inlet diameter and smaller outlet diameter. To obtain a desired height of discharge from the water fountain it is necessary to design a suitable nozzle for it.

In a nozzle, the exit velocity increases as per continuity equation  $Av=\text{constant}$  as given by Bernoulli equation (incompressible fluid). Pressure is inversely proportional to velocity, so we have lower pressure at the exit of the nozzle for higher velocity at the exit of the nozzle.

If the outlet is of smaller diameter, then the exit velocity will be higher as compared to the bigger diameter.

The main objectives are as follow:

1. To Reduce Nozzle wear problem
2. Reduce corrosion Problem
3. Reduce Turbulence Kinetic energy
4. The flow increase, the pressure drops, resulting larger spray particles then reduce leakage

## IV. RESEARCH METHODOLOGY

### 4.1 Observations

Total number of Nozzle	:	230
Outlet Diameter of Nozzle	:	15 mm
Inlet Diameter	:	2 mm
Height of Discharge	:	3.5 ft.
Power of Motor	:	10 HP
Level of water above motor	:	2 ft.
Time for unit discharge	:	4 sec
Volume of discharge	:	1 lt.

### 4.2 Analytical Calculation

Discharge through 1 nozzle

$$Q = \frac{\text{Volume}}{\text{time}}$$

$$\text{Or, } Q = \frac{4}{0.001}$$

$$\text{Or, } Q = 2.5 * 10^{-4} \text{ m}^3/\text{sec}$$

$$\text{Cross section area of inlet} = \frac{\pi}{4} * d_1^2 = \frac{\pi}{4} * 0.015^2 = 1.766 * 10^{-4} \text{ m}^2$$

$$\text{Cross section area of outlet} = \frac{\pi}{4} * d_2^2 = \frac{\pi}{4} * 0.002^2 = 3.14 * 10^{-6} \text{ m}^2$$

We know that,

$$\text{Discharge } Q = \text{area} * \text{velocity (At inlet condition)} \text{ Or, } 2.5 * 10^{-4} = 1.766 * 10^{-4} * V_1$$

$$\text{Or, } V_1 = 1.41 \text{ m/sec}$$

Hence the velocity of discharge at inlet = 1.41 m/sec

Table: 4.1 Nozzle Specifications

S.N	Nozzle	Inlet Diameter (mm)	Outlet Diameter (mm)	Height (mm)
1	Nozzle 1	15	2	70
2	Nozzle 2	15	2.5	70

4.33D Modeling of Nozzle on CATIA

The 3D model of nozzle was made on CATIA with the following dimensions: -

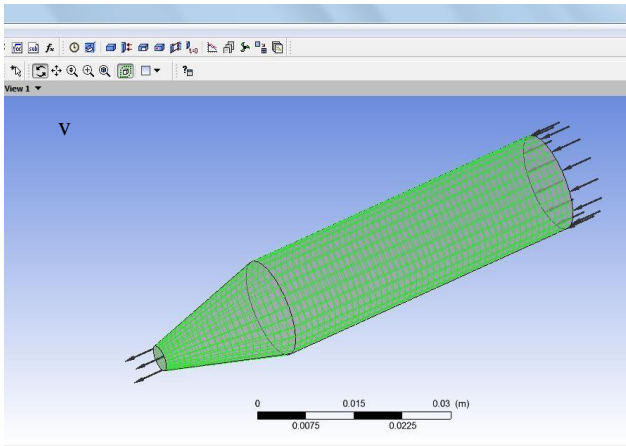

Figure: 4.1 3D model of Nozzle

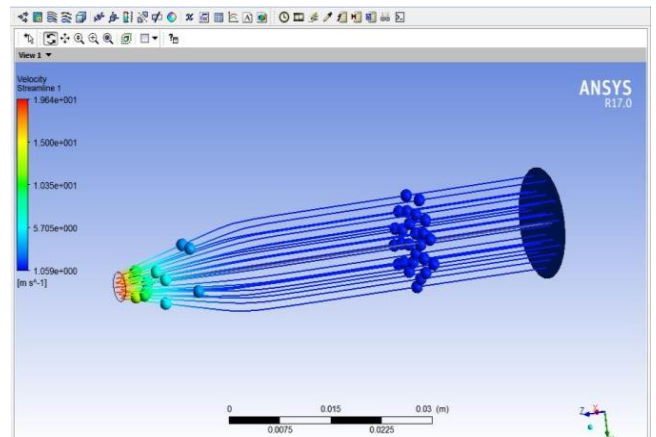

Figure: 4.2 Velocity Profile of 2mm Nozzle

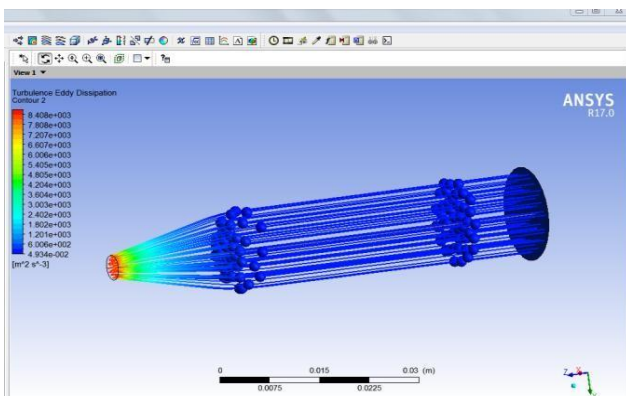

Figure: 4.3 Turbulence Eddy Dissipation of 2mm Nozzle

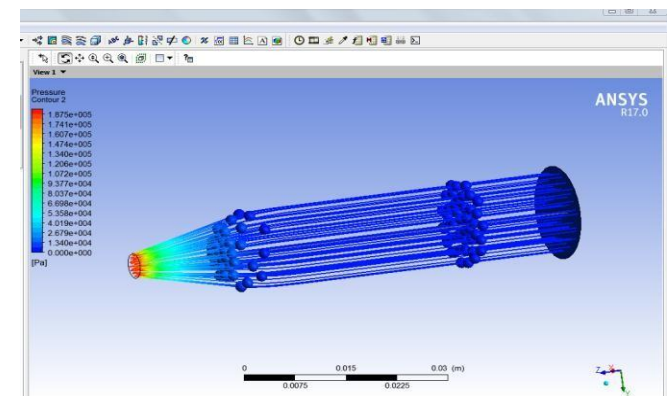

Figure: 4.4 Pressure Contour of 2mm Nozzle

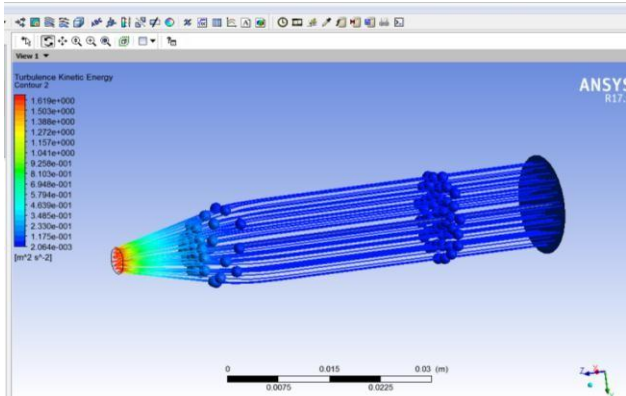

Figure: 4.5 Turbulence K.E. of 2mm Nozzle

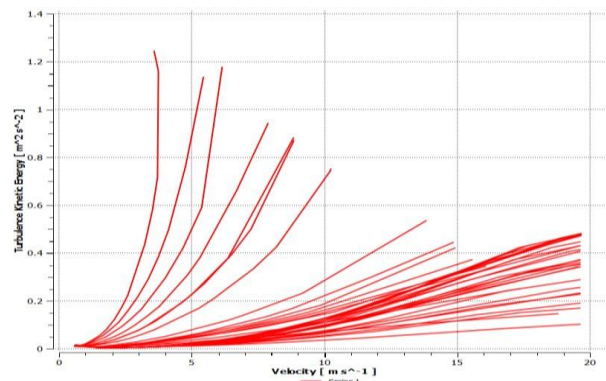

Figure: 4.6 Velocity Vs Turbulence Curve of 2 mm Nozzle

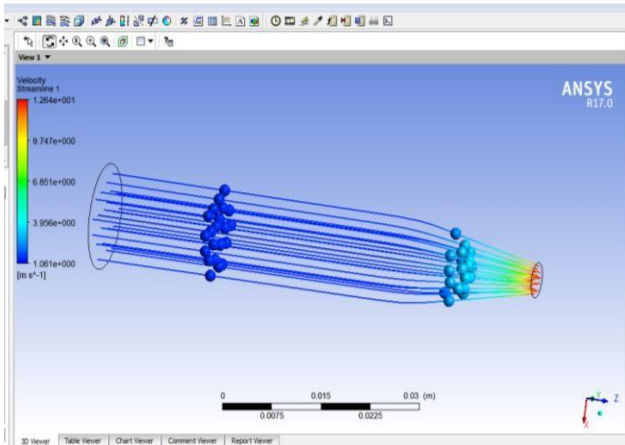

Figure: 4.7 Velocity Profile of 2.5 mm Nozzle

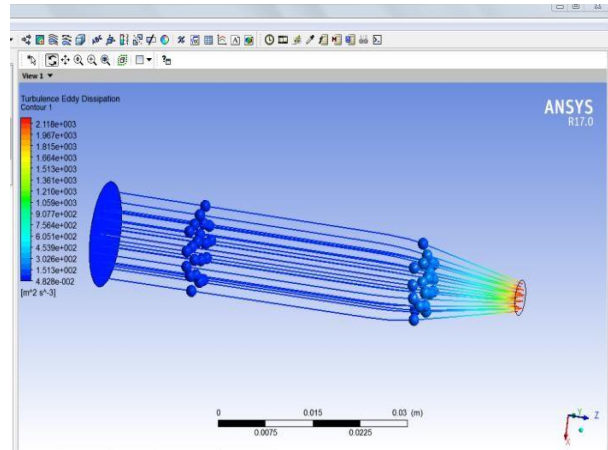

Figure: 4.8 Eddy viscosity profile of 2.5 mm Nozzle

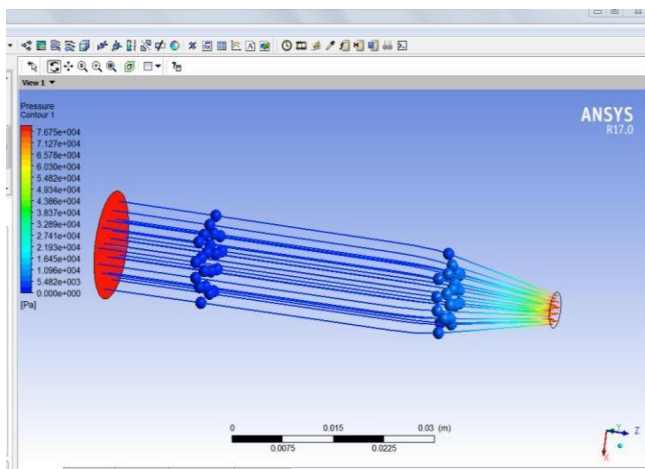

Figure: 4.9 Pressure Contour of 2.5 mm Nozzle

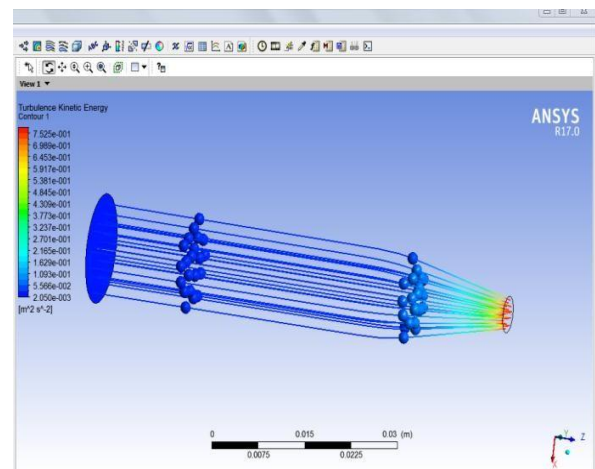

Figure: 4.10 Turbulence Kinetic Energy of 2.5 mm Nozzle

V. RESULT & DISCUSSION

Here We find that in CFD analysis of convergent nozzle with the help of ANSYS 17.0 version in which we can see that different parameters of flow like that velocity, pressure, viscosity, turbulence kinetic energy & eddy dissipation and in this study we have taken 2 nozzles with different diameter which is defined as nozzle 1 & nozzle 2 with respective outlet diameter of 2 mm & 2.5 mm.

Table 5.1 Comparison of Nozzles

Parameters	Nozzle 1 ( 2 mm)		Nozzle 2 ( 2.5 mm)	
	Max	Min	Max	Min
Velocity (m/s)	19.64	1.05	12.64	1.061
Pressure (Pa)	$1.875 \times 10^5$	$1.34 \times 10^4$	$7.67 \times 10^4$	$5.482 \times 10^3$
Turbulence K.E(m <sup>2</sup> s <sup>-2</sup> )	1.619	$2.064 \times 10^{-3}$	0.752	$2.05 \times 10^{-3}$
Viscosity ( Pa S)	$8.84 \times 10^{-2}$	$2.76 \times 10^{-3}$	$6.102 \times 10^{-2}$	$2.680 \times 10^{-3}$
Eddy Dissipation (m <sup>2</sup> s <sup>-3</sup> )	$8.40 \times 10^3$	$4.93 \times 10^{-2}$	$2.11 \times 10^3$	$4.82 \times 10^{-2}$

## VI. CONCLUSION

In this study we have found the maximum kinetic turbulence energy in case 1 compared to case 2.

So we will refer case 2 because here we found minimum kinetic turbulence energy and this work will be extended change in nozzle angle.

## VI. FUTURE SCOPE

This work can be successfully used in fluid machinery like water fountain, high pressure compressor and this work will be extended with the help of other computational fluid dynamic software like ALTAIR & ABACUS.

## REFERENCES

- [1] H. Syazwani et al 2016 —A review on nozzle wear in abrasive water jet machining applicationl Materials Science and Engineering 114 (2016) 012020
- [2] Saurabh Verma<sup>1</sup>, S. K. Mishra<sup>2</sup> and S.K. Moulick<sup>3</sup> , —CFD Analysis Of Nozzle In Abrasive Water Suspension Jet Machiningl International Journal of Advanced Engineering Research and Studies ,(2015), E-ISSN2249–8974
- [3] Bogdan-Alexandru Belega\*, Trung Duc Nguyen\*\* —Analysis Of Flow In Convergent-Divergent Rocket Engine Nozzle Using Computational Fluid Dynamicsl International Conference Of Scientific Paper Afases ,Brasov, 28-30 May 2015
- [4] Vincent Lijo, Numerical simulation of transient flows in a rocket propulsion nozzle, International Journal of Heat and Fluid Flow 31 (2010) 409-417
- [5] Mykhaylo Fedorov, Analytical study of steady-state compressible flow of perfect gas with constant heat flux and friction in constant area ducts, International Journal of Thermal science 49 (2010) 1277-1287
- [6] Alak Bandyopadhyay & Alok Majumdar, Modeling of Compressible Flow with Friction and Heat Transfer using the Generalized Fluid System Simulation Program (GFSSP), Sep 10-14 (2007).
- [7] Andrew Stewart Keir, Rob Ives, F A Hamad —CFD Analysis of C-D Nozzle compared with Theoretical & Experimental Datal Council of European Aerospace Societies, Aerospace Europe6th CEAS Conference, CEAS 2017 paper no. 943