



IJRTSM

INTERNATIONAL JOURNAL OF RECENT TECHNOLOGY SCIENCE & MANAGEMENT “DESIGN AND MODELING ON SHELL AND TUBE TYPE HEAT EXCHANGER BY USING DIFFERET BAFFLE GEOMETRY”

Shahid Razi ¹, Sunil Shukla ²

¹ M. Tech. Scholar, Department of Mechanical Engineering, NIRT. College, Bhopal, MP, India

². Assistant Professor, Department of Mechanical Engineering, NIIST, college, Bhopal, MP, India

ABSTRACT

Heat Exchangers are components that allow the transfer of heat from one fluid (liquid or gas) to another fluid. In a heat exchanger there is no direct contact between the two fluids. Here modeling of heat exchanger has done on Solidwork software and simulation has performed on Solidwork CFD platform. Hence the design can be changed for higher heat transfer rate results through positioning of baffles changing in our new design. So we are able to visible that when angle of inclination baffle might be extended then heat transfer we located that most. Right here we use 90⁰ circular baffles, 10⁰ degree inclination attitude with circular baffles, oval shape baffles and rectangular shape baffle. Here determined most heat transfer examine to 10⁰ degree inclination of baffles is best compare to all design.

Key Words: CFD, Solidwork, heat exchanger, heat, inclination.

I. INTRODUCTION

Warmth exchangers are one of the for the most element applied hardware inside the system ventures. Warmth exchangers are utilized to transport warmness between two interplay streams. You'll be able to understand their use that any interplay which encompass cooling, warming, buildup, bubbling or vanishing will require a warmth exchanger for those reason. Cycle beverages, most of the time are warmed or cooled earlier than the interplay or go through a degree trade. Special warmth exchangers are named via their utility. For instance, heat exchangers being applied to consolidate are known as condensers, likewise heat exchanger for bubbling reasons for current are known as boilers. Execution and proficiency of warmth exchangers are expected thru the degree of heat move using least space of warmth flow and urgent issue drop. An all of the greater higher display of its effectiveness is finished with the aid of figuring over all warmth flow coefficient. Pressing element drop and area wanted for a specific measure of heat circulate, offers a expertise approximately the capital fee and force conditions (jogging fee) of a warm temperature exchanger. For the maximum component, there may be bunches of writing and hypotheses to plot a warm temperature exchanger as indicated with the aid of the stipulations.

Warm temperature exchangers are of two sorts:-

- where both media among which warmth is traded are in direct contact with one some other is direct touch warmness exchanger,
- wherein each media are isolated by a divider thru which warmth is moved with the goal that they by no means blend, oblique contact heat exchanger.

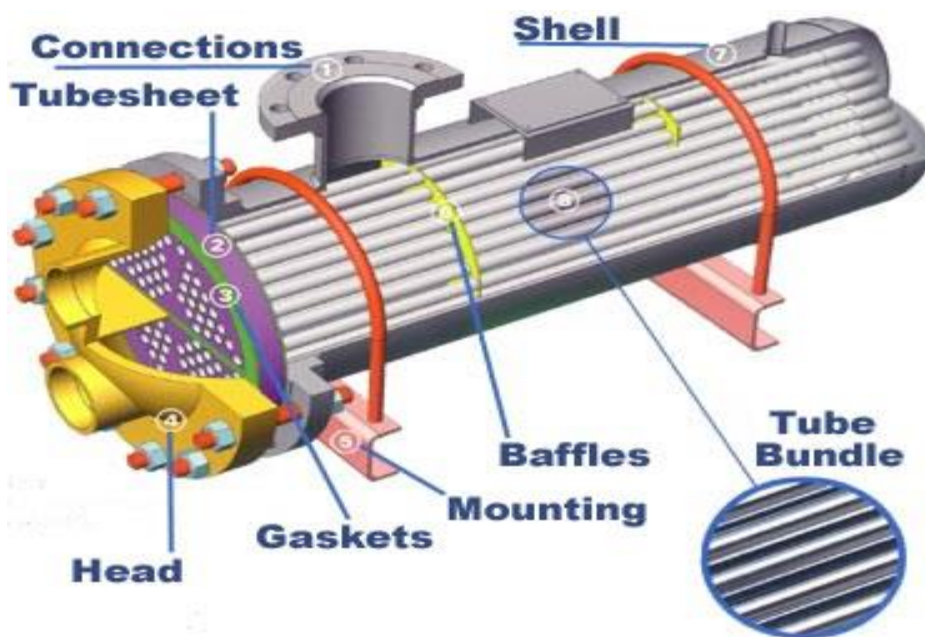

Fig.1.1 Shell and Tube Heat Exchanger

A regular warmth exchanger, commonly for better urgent factor applications up to 552 bars, is the shell and cylinder warmth exchanger. Shell and cylinder type warmth exchanger, backhanded contact kind warmth exchanger. It contains of a development of cylinders, via which one of the drinks runs. The shell is the compartment for the shell liquid. By means of and big, it's miles spherical and hollow match with a roundabout move segment, no matter the fact that shells of various shape are applied in explicit packages. For this specific investigation shell is notion of, that is for the most part a one bypass shell. A shell is the maximum usually utilized because of its minimum rate and effortlessness, and has the most extended log-suggest temperature-assessment (lmt_d) amendment factor. Albeit the cylinders can also have single or numerous passes, there may be one pass at the shell aspect, even as the opposite liquid streams inside the shell over the cylinders to be warmed or cooled. The cylinder aspect and shell side beverages are remoted with the aid of a cylinder sheet.

Bewilders are applied to assist the cylinders for number one inflexibility, forestalling tube vibration and placing and to redirect the circulation throughout the p.C. To gather a higher warm temperature flow coefficient. Perplex dividing (b) is the center line distance among two close by confuses, baffle is supplied with a cut (bc) that is communicated as the level of the component stature to shell internal breadth. Astound reduce can shift somewhere in the variety of 15% and forty five% of the shell inner breadth. Within the contemporary examination 36% perplex cut (bc) is concept of. By and massive, conventional shell and cylinder warmth exchangers result in excessive shell-facet urgent thing drop and association of distribution zones close to the perplexes.

A big portion of the explores now each day are endured astounds, which provide better execution then, at that point unmarried segmental confounds but they consist of excessive assembling value, established order fee and protection cost. The adequacy and price are two substantial limitations in warmth exchanger plan. Alongside these strains, in request to enhance the nice and cozy presentation at a realistic rate of the shell and cylinder heat exchanger, perplexes inside the cutting-edge exam are furnished with a few tendency to preserve a realistic pressing factor drop across the exchanger.

The intricacy with check strategies includes quantitative portrayal of movement marvels utilising estimations handling every amount in turn for a restricted scope of problem and operating situations. Computational fluid dynamics is currently a set up current plan device, providing clear advantages. On this examination, a full 360° cfd version of shell and cylinder warmth exchanger is concept of. Through displaying the calculation as exactly as could be expected, the move shape and the temperature dispersion in the shell are received.

II. METHODOLOGY

SOLUTION:

Arrangement Method

- Pressure Velocity coupling plan
For 2D Problem we use Stream Function Vortices approach.
For 3D Problem we use SIMPLEC approach.
Arranged network ought to be utilized to tackle pressure speed coupling plan.
- Turbulence Modeling:-
(k-epsilon 2 eqn).model for violent stream condition
Force second request
Choppiness Kinetic energy second request (K)
Choppiness dispersal rate second request (ϵ)
- SOLUTION INITIALIZATION:-
Introduced the answer for get the underlying answer for the issue.
By utilizing SIMPLE solver (Semi – understood technique for pressure connected condition
- RUN SOLUTION:-
Show the answer for giving 100 no of cycle for answer for unite.
- POST PROCESSING:-
- Post Processing:- For survey and translation of Result, the outcome can be seen in different configurations like chart, esteem, activity .

III. MODELING

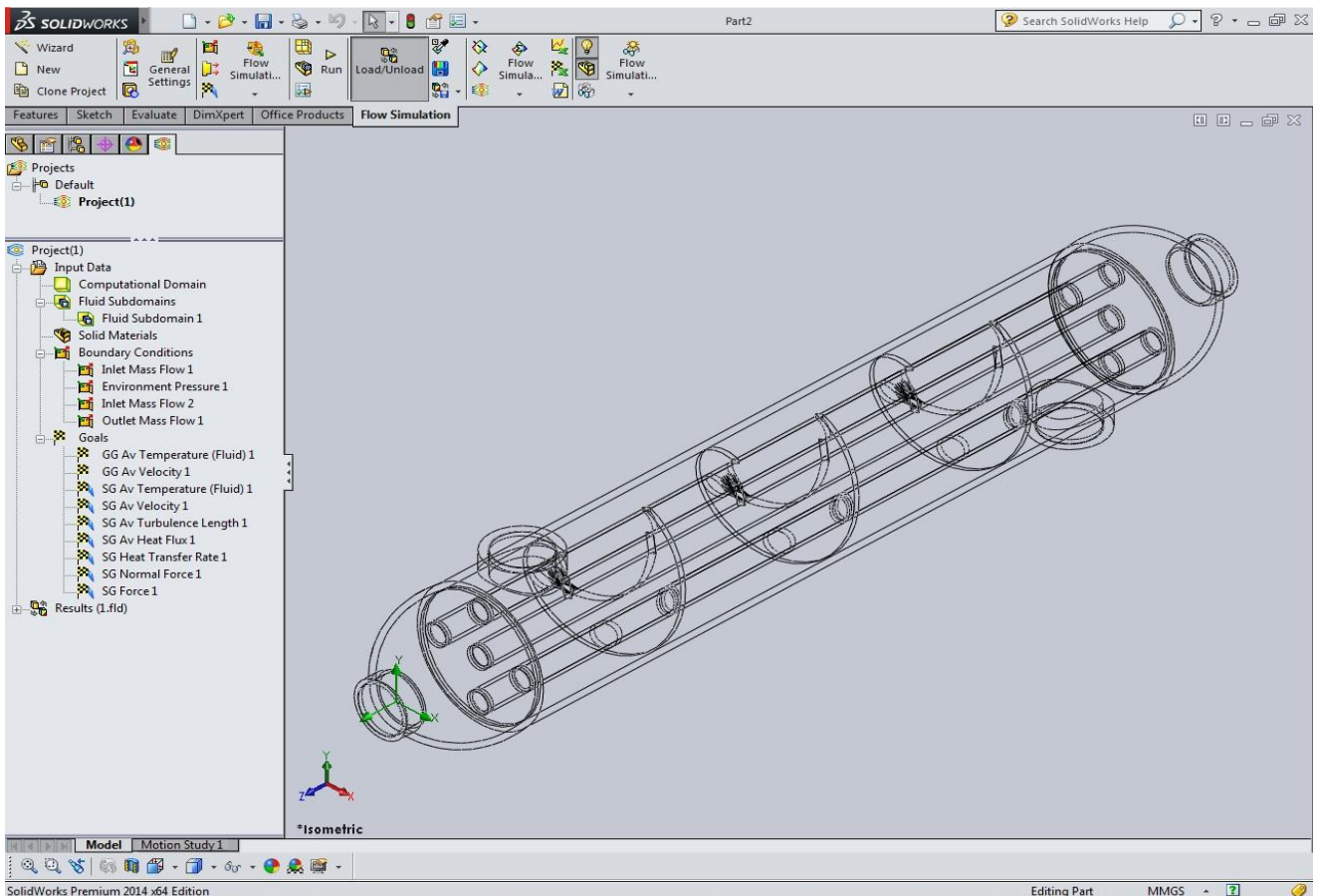

Fig 3.1 3D model for a shell and tube exchanger

IV. SIMULATION

Under the above restrict situation and arrangement introduce condition replica was set for 100 cycle.

4.1 CONVERGENCE OF SIMULATION:

The intermingling of simulation is needed to get the bounds of the shell and cylinder heat exchanger in outlet. It moreover offers particular worth of boundaries for the necessity of heat flow rate. Congruity, x-speed, y-speed, z-pace, strength, okay , epsilon are the piece of scaled leftover which need to unite in a selected locale. For the development pace, y-pace, z-pace , okay, epsilon need to be below 10^{-4} and the energy must be under 10^{-7} . Assuming those all traits in equal manner, association can be united. 180 degree baffle dispositions .

For 180 degree diploma astound tendency association turned into united at a hundredth emphasis. The accompanying determine shows the remaining plot for the above emphases:

180⁰ Baffle inclinations:

Simulation of 180⁰ baffle inclination is converged at 100th iteration. The following figure shows the residual plot:

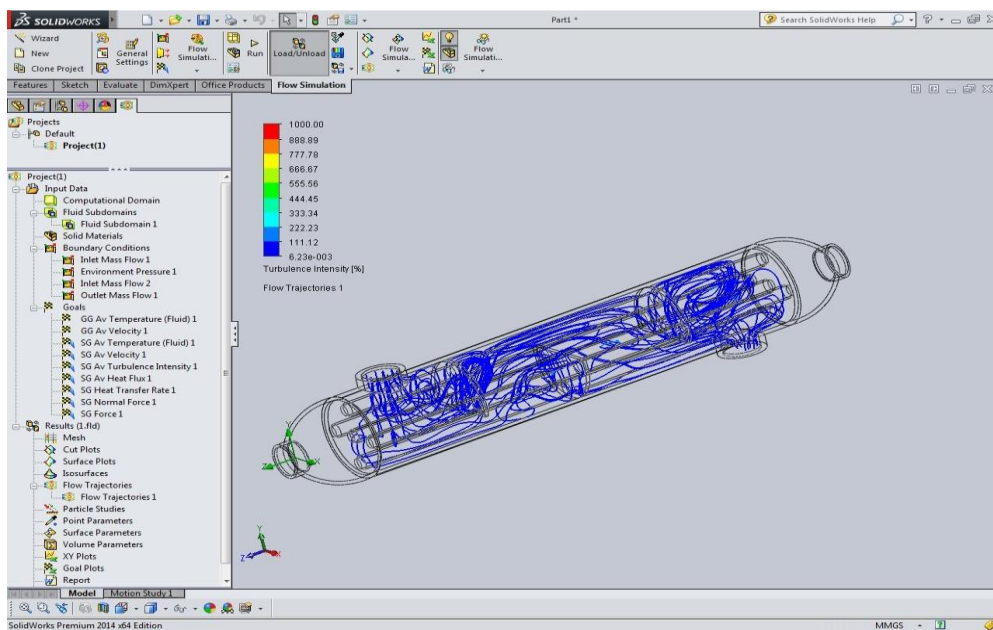

Fig.4.1 Circular Baffles Turbulence Results

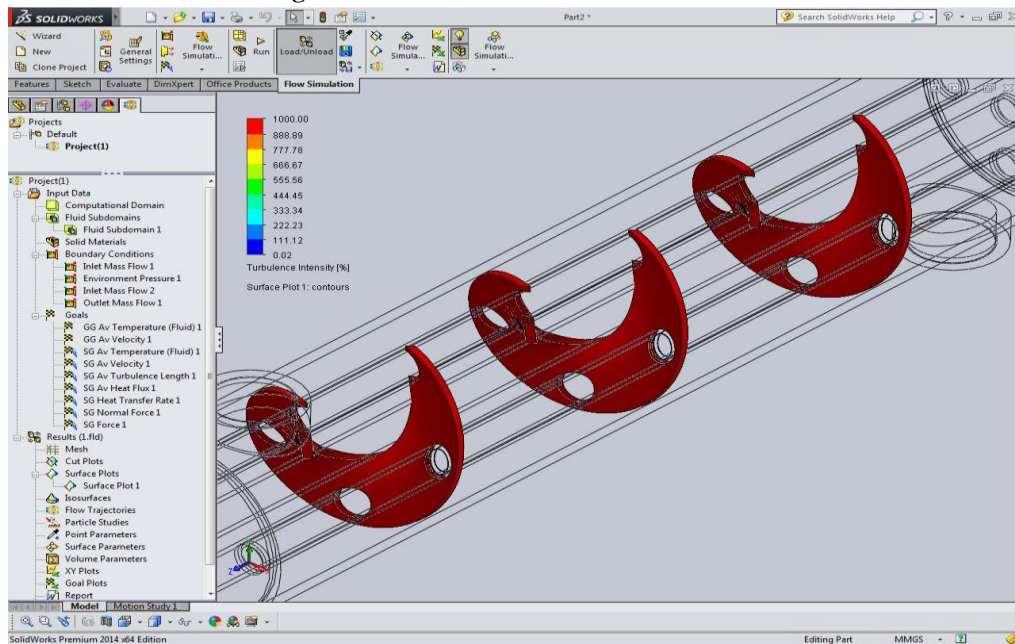

Fig. 4.2 10 degree inclined Circular Baffles Turbulence Results

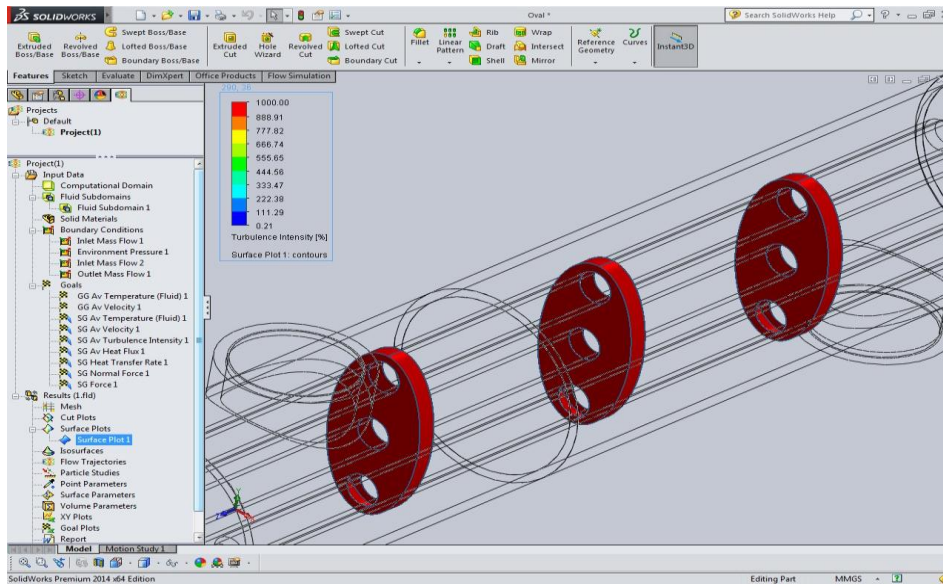

Fig.4.3 Oval Shape Baffles Turbulence Results

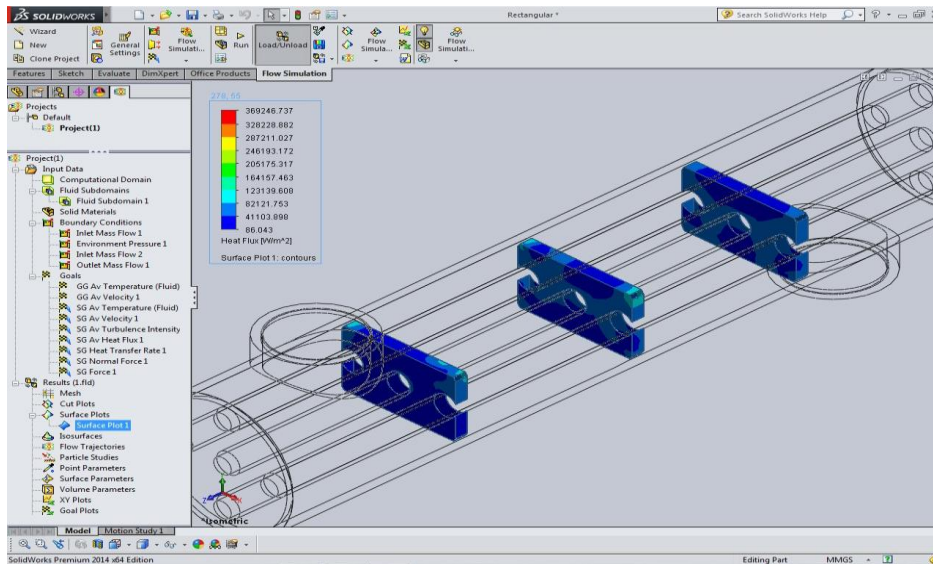

Fig.4.4 Rectangular Shape Baffles Heat flux Results

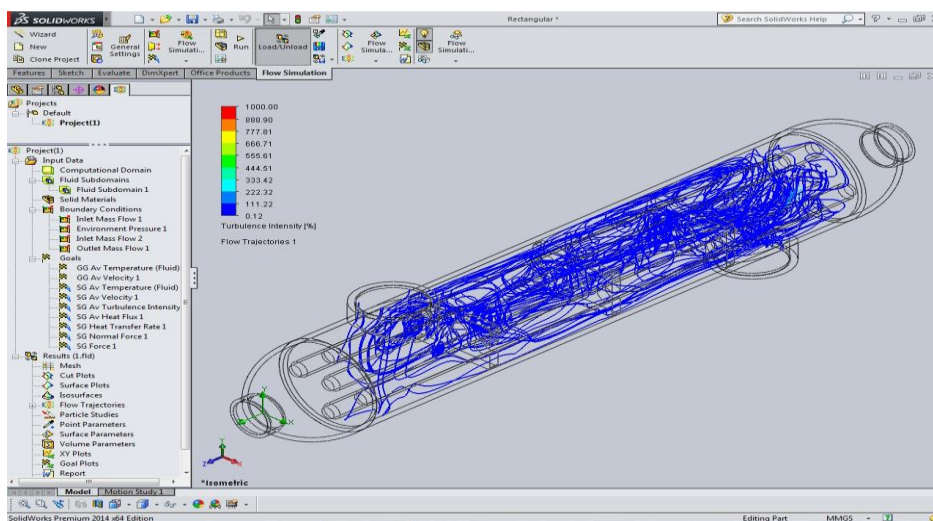

Fig.4.5 Rectangular Shape Baffles Turbulence Results

V. RESULTS & DISCUSSION

Heat Exchangers are components that allow the transfer of heat from one fluid (liquid or gas) to another fluid. In a heat exchanger there is no direct contact between the two fluids. Here modeling of heat exchanger has done on Solidwork software and simulation has performed on Solidwork CFD platform. Hence the design can be changed for higher heat transfer rate results through positioning of baffles changing in our new design. So we are able to visible that when angle of inclination baffle might be extended then heat transfered we located that most. Right here we use 90° circular baffles , 10° degree inclination attitude with circular baffles, oval shape baffles and rectangular shape baffle. Here variour results find out like, temperature, heat flux, turbulence, etc so basis on heat transfer rate is more 10 degree baffles arrangement design So Here determined most heat transfer examine to 10° degree inclination of baffles is best compare to all design.

VI. RESULTS & DISCUSSION

Actually exiting design was based on straight type baffles but in new design used different shapes of baffles and inclination of baffle with 10 degree find out best results to compare to all geometries.

VII. CONCLUSION

The Heat Exchanger and go with the flow distribution is discussed in element and proposed version is in comparison this version also can be progressed by using the usage of nusselt variety and Reynolds pressure model, but with better computational concept. Furthermore the decorate wall feature are not use on this undertaking, however they may be very useful. The warmth switch is poor due to the fact most of the fluid passes with out the interplay with baffles. Hence the design can be changed for higher warmness switch in approaches both the decreasing the shell diameter, which will be a right touch with the baffle or by using growing the baffle in order that baffles could be right touch with the shell. It's miles due to the fact the heat switch region isn't utilized correctly. So we are able to visible that when angle of inclination baffle might be extended then heat transfered we located that most. Right here we use 90° circular baffles , 10° degree inclination attitude with circular baffles, oval shape baffles and rectangular shape baffle .we determined most heat transfer examine to 10° degree inclination of baffles is best compare to all design.

REFERENCES

1. Shuvam Mohanty, R. Arora“CFD Analysis of a Shell and Tube Heat Exchanger with Single Segmental Baffles”, International Journal of Automotive and Mechanical Engineering 17(2):7890-7901, july 2020
2. Nada SA, Elattar HF, Fouda A, Refaey HA. Numerical investigation of heat transfer in annulus laminar flow of multi tubes-in-tube helical coil. Heat and Mass Transfer. ; 54(3):715-26, 2018
3. Pal E, Kumar I, Joshi JB, Maheshwari NK. CFD simulations of shell-side flow in a shell-and-tube type heat exchanger with and without baffles. Chemical engineering science. 2016; 143:314-40.2016
4. Bhadouriya R, Agrawal A, Prabhu SV. Experimental and numerical study of fluid flow and heat transfer in a twisted square duct. International Journal of Heat and Mass Transfer. 2015; 82:143-58
5. A.O. Adelaja, s. J. Ojolo and m. G. Sobamowo, "computer aided analysis of thermal and mechanical design of shell and tube warmth exchangers", superior materials vol. 367 (2012) pp 731-737 © (2012) trans tech publications, switzerland.
6. Yusuf ali kara, ozbilen guraras, "a computer software for planning of shell and cylinder heat exchanger", implemented thermal engineering 24(2004) 1797–1805.
7. Rajagopal thundil karuppa raj and srikanth ganne, "shell side numericalanalysis of a shell and cylinder warmness exchanger considering the impacts of confound tendency factor on liquid circulate", thundil karuppa raj, r., et al.: shell aspect numerical evaluation of a shell and tube heat exchanger ,thermal technology: year 2012, vol. Sixteen, no. Four, pp. 1165-1174.
8. S. Noie baghban, m. Moghiman and e. Salehi, " thermal investigation of shell-side progression of shell-and cylinder warmness exchanger utilising trial and hypothetical techniques" (received: october 1, 1998 - usual in revised shape: june 3, 1999).

9. A.Gopichand, prof.A.V.N.L.Sharma , g.Vijay kumar, a.Srividya, " thermal exam of shell and cylinder heat exchanger using mat lab and floefd programming", extent: 1 problem: three 276 – 281, issn: 2319 – 1163.
10. Hari haran, ravindra reddy and sreehari, "heat analysis of shell and tube warmth exchanger using c and ansys" , global magazine of pc traits and technology (ijctt) – volume 4 problem 7–july 2013.
11. Christopher ian wright, "compelling administration of warmth pass liquid glimmer point temperatures utilizing a mild-closes evacuation % (lerk)", case research in thermal engineering, vol. Four, pp. Nine–14, 2014.
12. M. C. Weikla, okay. Braunb and j. Weiss, "curl wound warmth exchangers for liquid salt applications", power procedia, vol. Forty nine, pp. 1054 – 1060, 2014.
13. Tonio sant and robert n. Farrugia, "showing the strength yield enhancement from a wind turbine at a deep offshore low wind website through mixed electricity and thermocline strength manufacturing", magazine of sun electricity engineering, vol. 137/011002, pp. 1-8, 2015.